

Flap Stay Fitting Lift 90 Alu for 19mm Aluminium Profile



Top box hinge Lift 90

Spring force 180 N,
opening angle 90°

The flap swings up 90° and is held open in this position -
to provide optimum access to the cabinet interior.

Efficient hole line assembly

Max. flap weight: 3.3 kg

Zinc-plated steel

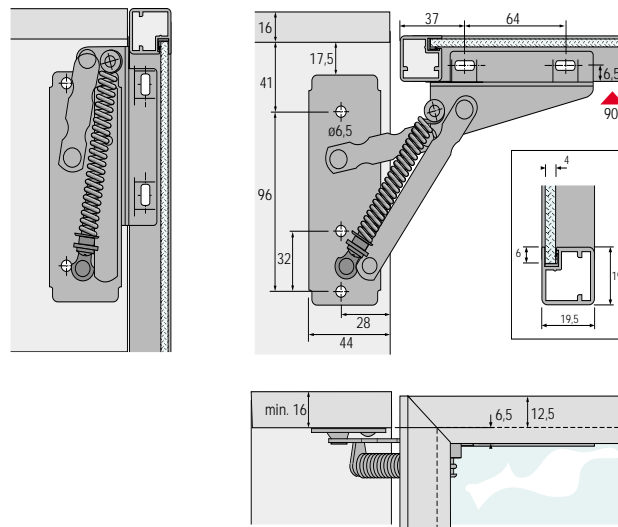

Top box hinge Lift 90 opening angle 90°

Article	Order no.	PU
Top Box Hinge Lift 90 opening angle 90°	079 390	10

Recommended Fixing
screw: 6g Pan head
self tapper. Pilot Hole
size of 2.5mm
diameter required
for Fixing screws.



Mitchell Laminates

Mitchell Laminates
32-38 Redwood Drive
Dingley VIC 3172
Telephone (03) 9558 0800
Facsimile (03) 9558 0557
sales@mitchelllaminates.com.au

Branch:
37-53 Crockford Street
Port Melbourne VIC 3207
Telephone (03) 9646 7877
Facsimile (03) 9646 7570

Hettich recommends **Alifrost** Doors

9993984 We reserve the right to make technical changes without notice.
While we have done our best to ensure the accuracy of the catalogue data, we take no responsibility for printing or other errors.

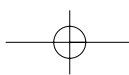

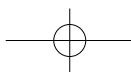

Flap Stay Fitting Lift 90 for 55mm Aluminium Profile



Flap Stay Lift 90

Spring force 180 N,
opening angle 90°

The flap swings up 90° and is held open in this position -
to provide optimum access to the cabinet interior.

Efficient hole line assembly

Max. flap weight: 3.3 kg

Zinc-plated steel

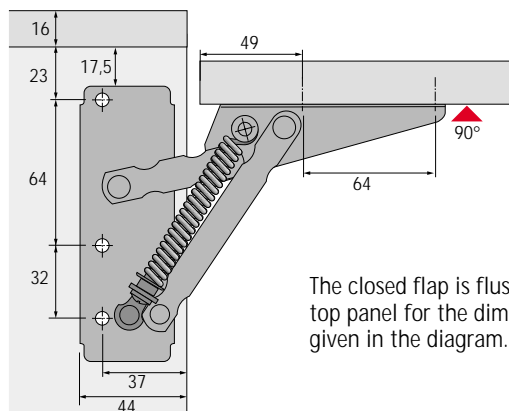
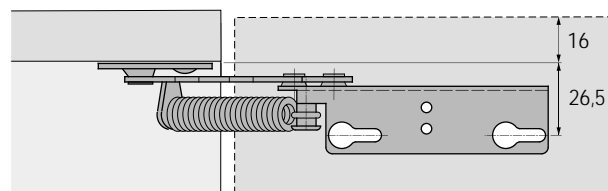

The closed flap is flush with the
top panel for the dimensions
given in the diagram.

Top box hinge Lift 90 opening angle 90°

Recommended Fixing
screw: 8g Pan head
self tapper. Pilot Hole
size of 3.5mm
diameter required
for Fixing screws.

Article	Order no.	PU
Top Box Hinge Lift 90	079 389	10



Mitchell Laminates

Mitchell Laminates
32-38 Redwood Drive
Dingley VIC 3172
Telephone (03) 9558 0800
Facsimile (03) 9558 0557
sales@mitchelllaminates.com.au

Branch:
37-53 Crockford Street
Port Melbourne VIC 3207
Telephone (03) 9646 7877
Facsimile (03) 9646 7570

Hettich recommends **Alifrost** Doors

9993983 We reserve the right to make technical changes without notice.
While we have done our best to ensure the accuracy of the catalogue data, we take no responsibility for printing or other errors.

